



elements Mobiles-V2 Assembly Instructions

elements Mobile-V2 Assembly Instructions

PARTS:

- > Framed Panel (1)
- > Feet (2)
- > Locking Casters (2)
- > Non-Locking Casters (2)
- > Spacer Donuts (4)
- > M6 x 1-35mm Flat Head Screws (4)
- > M6 x 1-25mm Flat Head Screws (6)

TOOLS NEEDED:

- > 4mm Allen Wrench
- > 13mm Wrench
- > Flat Protected Work Surface

ASSEMBLY:

- Carefully lay the framed panel on a protected surface with the bottom (the end with tapped holes) hanging over the edge of the surface.
- Using a 4mm Allen wrench, remove any screws already installed in the bottom.
- Attach the feet to the bottom of the framed panel. The 35mm screws will be used in the 2 holes toward the outside edge of the panel on each foot. The 25mm screws will be used in the 3 interior holes on each foot. (IMAGE 1)

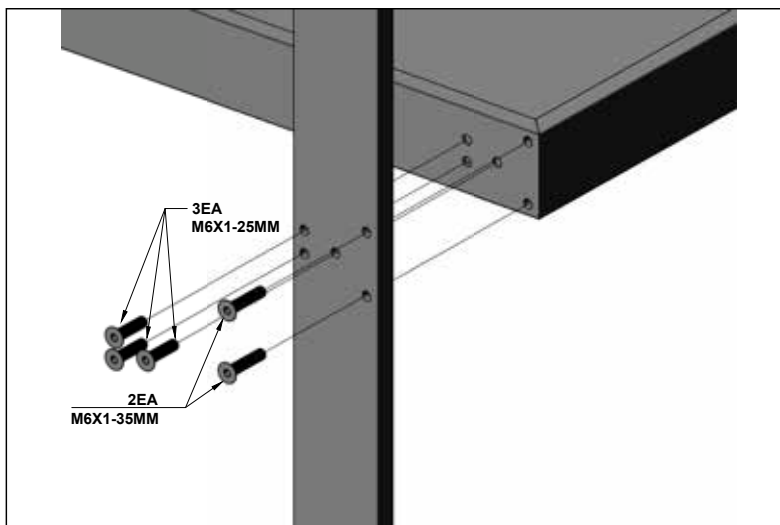

(IMAGE 1)

elements Mobile-V2 Assembly Instructions

ASSEMBLY:

- With the spacer donut around the threaded stem of the caster, thread the casters into each foot. Tighten with a 13mm wrench. (IMAGE 2)

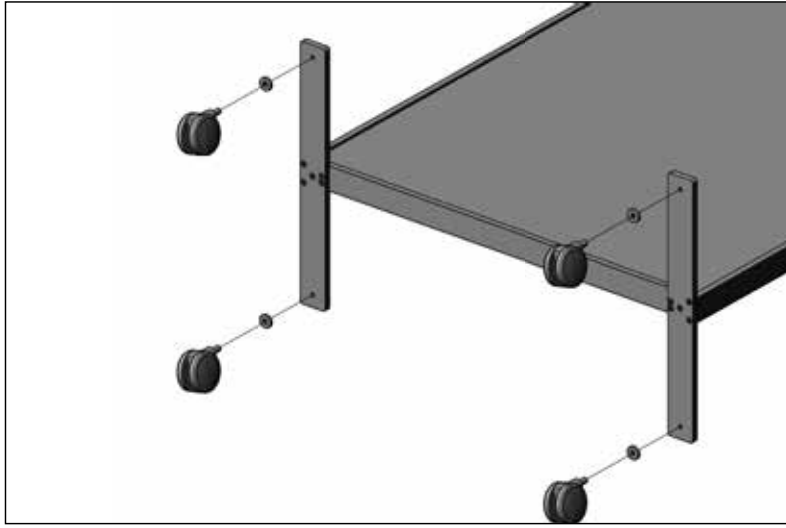

(IMAGE 2)

- With the help of another person, lift and place the screen upright.